

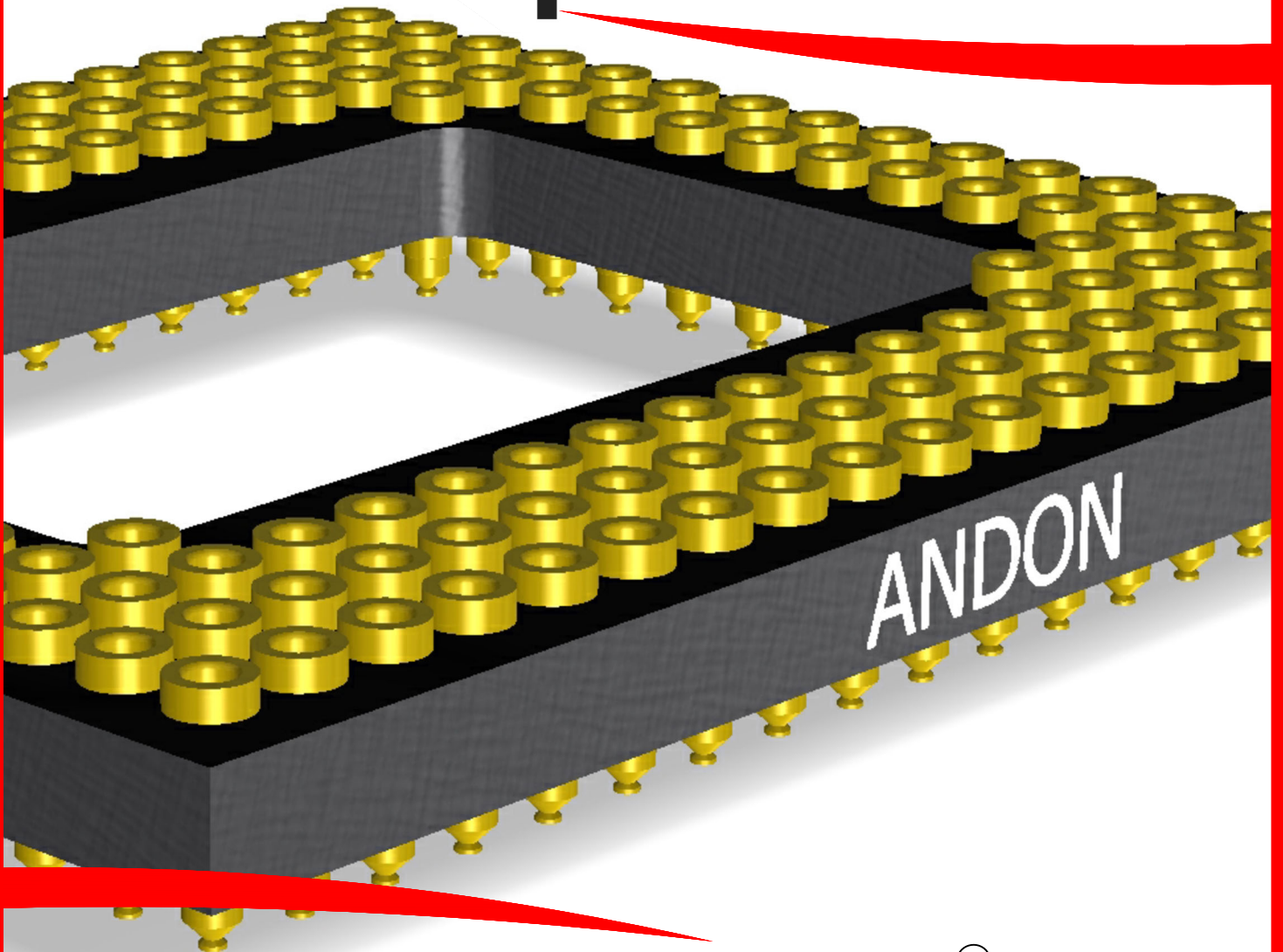

***High-Reliability Image Sensor Sockets
for Gpixel Inc.***

Gpixel



Featuring Andon's Unique SenstacTM Contact

GPIXEL INC.							
GPIXEL INC. Model Number	Andon Part Number Replace "XXX" with Terminal Type	Terminal Type			Pin Ø [in]	Figure Number	Page Number
		Thru-Hole	Surface Mount	Rollerball®			
GCINE4349	692-431-XX-XXX-R27-L14-X	TH-491	SM-500	SM-RB593	-	22	8
GL0402	694D-76-XX-XXX-R27-L14-X	TH-491	SM-500	SM-RB593	-	13	4
GL0816	10-37-01-258-XXX-R27-L14	400T4	414T4	RB501T4	.012	6	3
GLT5009BSI	10-45-01-269-XXX-R27-L14	400T4	414T4	RB501T4	.012	20	7
GLUX1605BSI	684-84-XX-XXX-R27-L14-1	TH-491	SM-500	SM-RB593	-	21	7
GLUX9701BSI	684-84-XX-XXX-R27-L14-1	TH-491	SM-500	SM-RB593	-	21	7
GMAX0505	694-230B-XX-XXX-R27-L14-1	TH-491	SM-500	SM-RB593	-	1	1
GMAX0806	10-24-10A-183-XXX-R27-L14	400T4	414T4	RB501T4	.012	5	2
GMAX2505	694-230D-XX-XXX-R27-L14-1	TH-491	SM-500	SM-RB593	-	15	5
GMAX2509	694-230D-XX-XXX-R27-L14-1	TH-491	SM-500	SM-RB593	-	15	5
GMAX2518	694-230E-XX-XXX-R27-L14-1	TH-491	SM-500	SM-RB593	-	16	6
GMAX32103	10-35-07A-209-XXX-R27-L14	400T4	414T4	RB501T4	.012	17	6
GMAX32152	10-46-03-183-XXX-R27-L14	400T4	414T4	RB501T4	.012	8	3
GMAX3265	10-26-40-239-XXX-R27-L14	400T4	414T4	RB501T4	.012	11	4
GMAX3809	694-163B-XX-XXX-R27-L14-1	TH-491	SM-500	SM-RB593	-	14	5
GMAX4651	585-19-23-238-XXX-R27-L14	75M	384M	-	.018	12	4
GSENSE1516BSI	575-27-01-323-XXX-R27-L14	01P28	93P28	RB338K	.018	18	6
GSENSE2011	10-18-04A-153-XXX-R27-L14	400T4	414T4	RB501T4	.012	2	2
GSENSE2020BSI	10-18-04A-153-XXX-R27-L14	400T4	414T4	RB501T4	.012	2	2
GSENSE2020	10-18-04A-153-XXX-R27-L14	400T4	414T4	RB501T4	.012	2	2
GSENSE400	575-13-87-115-XXX-R27-L14	01M	93M	RB338K	.018	3	2
GSENSE400	575-13-87A-115-XXX-R27-L14	01M	93M	RB338K	.018	3	2
GSENSE400BSI	575-13-87-115-XXX-R27-L14	01M	93M	RB338K	.018	3	2
GSENSE400BSI	575-13-87A-115-XXX-R27-L14	01M	93M	RB338K	.018	3	2
GSENSE4040/4040BSI	575-20-21A-140-XXX-R27-L14	01M	93M	RB338K	.018	4	2
GSENSE6060/6060BSI	575-38-03A-250-XXX-R27-L14	01M	93M	RB338K	.018	10	3
GSPRINT4502	10-20-06-255-XXX-R27-L14	400T4	414T4	RB501T4	.012	23	8
GSPRINT4510	9-10-30-15-454-XXX-R27-L14-SIP	274UM	315UM	RB338UM	.012	19	7
GSPRINT4521	9-10-30-15-454-XXX-R27-L14-SIP	274UM	315UM	RB338UM	.012	19	7

Patented Heat Sink Sockets™ (socket with heat sink feature)

GPIXEL LNC.							
GPIXEL Model Number	Andon Part Number Replace "XXX" with Terminal Type	Terminal Type			Pin Ø [in]	Figure Number	Page Number
		Thru-Hole	Surface Mount	Rollerball®			
GMAX32103	10-35-07-209-XXX-R27-L14-HS1	400T4	-	-	.012	25	10
GSPRINT4510	10-30-15-454-XXX-R27-L14-HS1	275UM	-	-	.012	24	10
GSPRINT4521	10-30-15-454-XXX-R27-L14-HS1	275UM	-	-	.012	24	10

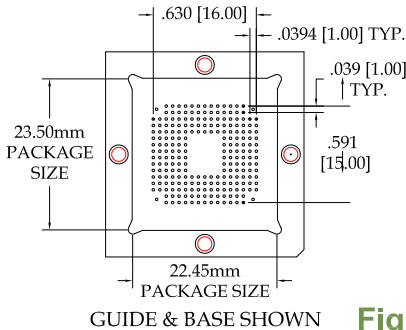
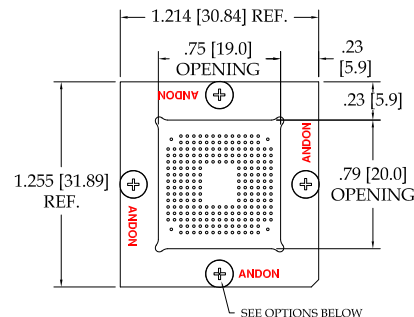

Fig. 1 230 Pins

Thru-Hole: 694-230B-TH-491-R27-L14-1
Surface Mount: 694-230B-SM-500-R27-L14-1
Rollerball®: 694-230B-SM-RB593-R27-L14-1



COVER & HARDWARE SHOWN

©Copyright 2023 Andon Electronics Corporation. All Rights Reserved. This material is protected under US and other copyrights and may not be copied, sold, or redistributed in any form without written permission of Andon Electronics Corporation. Copyrights and trademarks are property of their respective companies. We reserve the right to change specifications without notice. Andon makes no warranty, expressed or implied, as to the suitability of the sockets for the intended purpose.

Rollerball® U.S. PATENT CANADIAN PATENT

"ANDON PROPRIETARY INFORMATION"
RoHS Compliant

*Sockets are not drawn to scale GPIXEL INC. 05/10/2023

GPIXEL INC. *Continued*

Image Sensor Socket Footprints

Units: in [mm]

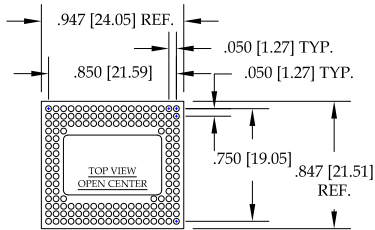

Fig. 2 **153 Pins**
Thru-Hole: 10-18-04A-153-400T4-R27-L14
Surface Mount: 10-18-04A-153-414T4-R27-L14
Rollerball®: 10-18-04A-153-RB501T4-R27-L14

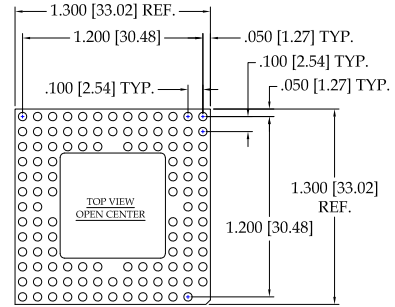

Fig. 3 **115 Pins**
Thru-Hole: 575-13-87-115-01M-R27-L14
Surface Mount: 575-13-87-115-93M-R27-L14
Rollerball®: 575-13-87-115-RB338K-R27-L14
WITH OPTIONAL WINDOW SHOWN
Thru-Hole: 575-13-87A-115-01M-R27-L14
Surface Mount: 575-13-87A-115-93M-R27-L14
Rollerball®: 575-13-87A-115-RB338K-R27-L14

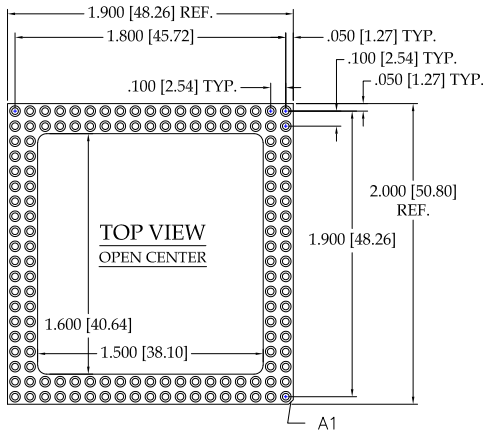

Fig. 4 **140 Pins**
Thru-Hole: 575-20-21A-140-01M-R27-L14
Surface Mount: 575-20-21A-140-93M-R27-L14
Rollerball®: 575-20-21A-140-RB338K-R27-L14

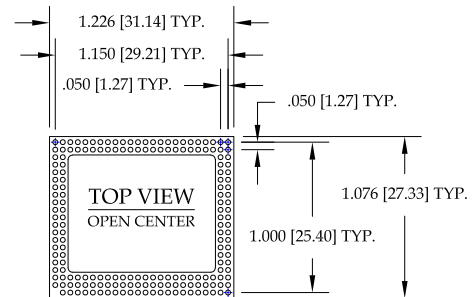

Fig. 5 **183 Pins**
Thru-Hole: 10-24-10A-183-400T4-R27-L14
Surface Mount: 10-24-10A-183-414T4-R27-L14
Rollerball®: 10-24-10A-183-RB501T4-R27-L14

GPIXEL INC. *Continued* Image Sensor Socket Footprints Units: in [mm]

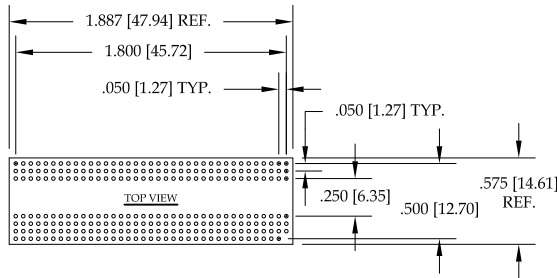

Fig. 6 **258 Pins**
Thru-Hole: 10-37-01-258-400T4-R27-L14
Surface Mount: 10-37-01-258-414T4-R27-L14
Rollerball®: 10-37-01-258-RB501T4-R27-L14

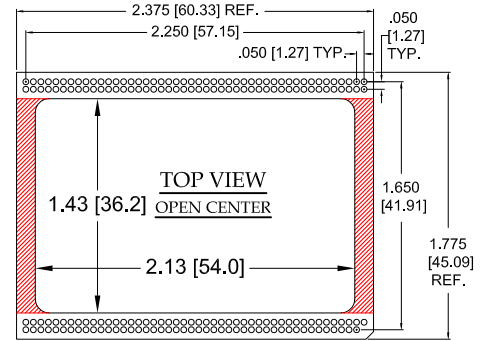

Fig. 8 **183 Pins**
Thru-Hole: 10-46-03-183-400T4-R27-L14
Surface Mount: 10-46-03-183-414T4-R27-L14
Rollerball®: 10-46-03-183-RB501T4-R27-L14

REFER TO LAST PAGE FOR CARRIER OPTIONS
 RED SECTIONS OF INSULATOR CAN BE OMITTED AND
 THIS CARRIER USED IN THEIR PLACE:

Carrier/Sips: 9-10-46-03-183-XXX-R27-L14-SIP

Replace "-XXX" with
 choice of terminal

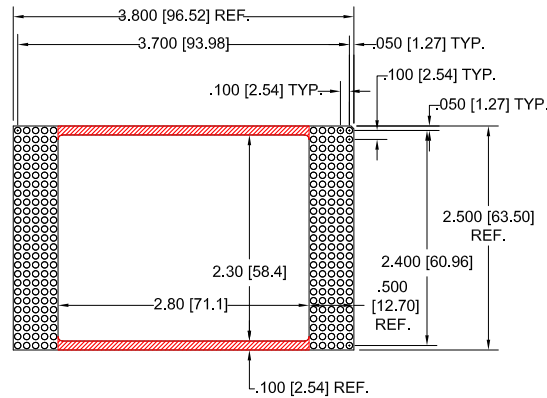

Fig. 10 **250 Pins**
Thru-Hole: 575-38-03A-250-01M-R27-L14
Surface Mount: 575-38-03A-250-93M-R27-L14
Rollerball®: 575-38-03A-250-RB338K-R27-L14

REFER TO LAST PAGE FOR CARRIER OPTIONS
 RED SECTIONS OF INSULATOR CAN BE OMITTED AND
 THIS CARRIER USED IN THEIR PLACE:

Carrier/Sips: 9-575-38-03A-250-XXX-R27-L14-SIP

Replace "-XXX" with
 choice of terminal

GPIXEL INC. *Continued* Image Sensor Socket Footprints Units: in [mm]

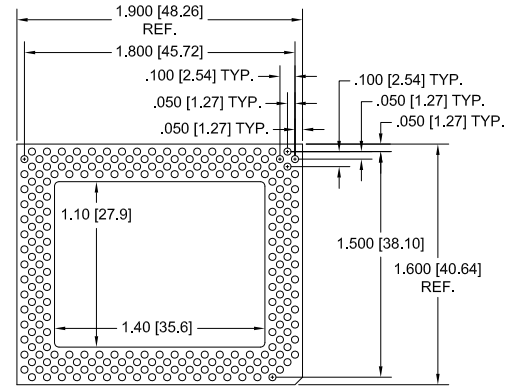
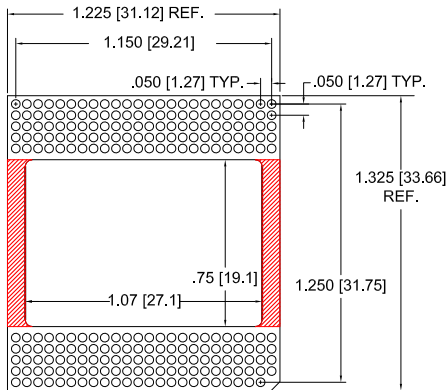

Fig. 11 **239 Pins**

- Thru-Hole:** 10-26-40-239-400T4-R27-L14
- Surface Mount:** 10-26-40-239-414T4-R27-L14
- Rollerball®:** 10-26-40-239-RB501T4-R27-L14

REFER TO LAST PAGE FOR CARRIER OPTIONS
RED SECTIONS OF INSULATOR CAN BE OMITTED AND
THIS CARRIER USED IN THEIR PLACE:

Carrier/Sips: 9-10-26-40-239-XXX-R27-L14-SIP

Replace "XXX" with
choice of terminal

Fig. 12 **238 Pins**

- Thru-Hole:** 585-19-23-238-75M-R27-L14
- Surface Mount:** 585-19-23-238-384M-R27-L14

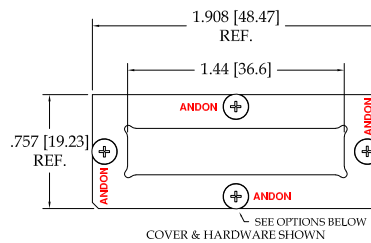
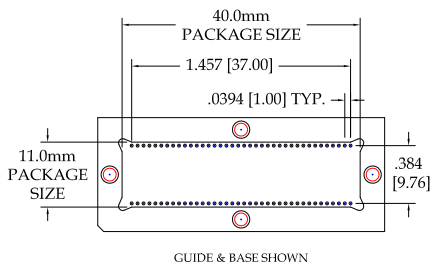

Fig. 13 **76 Pins**

- Thru-Hole:** 694D-76-TH-491-R27-L14-1
- Surface Mount:** 694D-76-SM-500-R27-L14-1
- Rollerball®:** 694D-76-SM-RB593-R27-L14-1

GPIXEL INC. *Continued*

Image Sensor Socket Footprints

Units: in [mm]

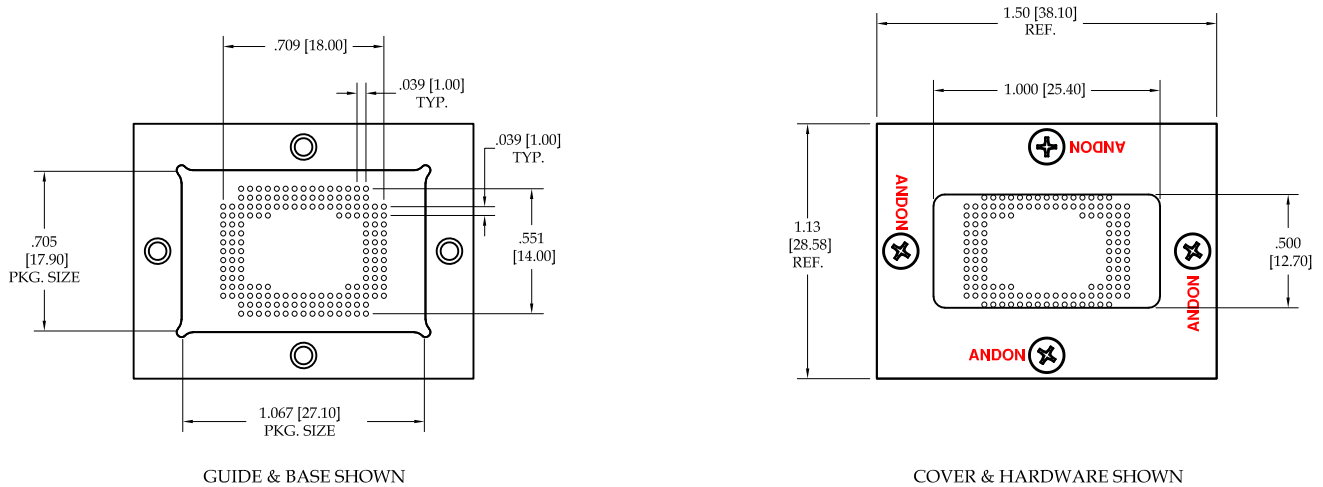

Fig. 14 163 Pins
Thru-Hole: 694-163B-TH-491-R27-L14-1
Surface Mount: 694-163B-SM-500-R27-L14-1
Rollerball®: 694-163B-SM-RB593-R27-L14-1

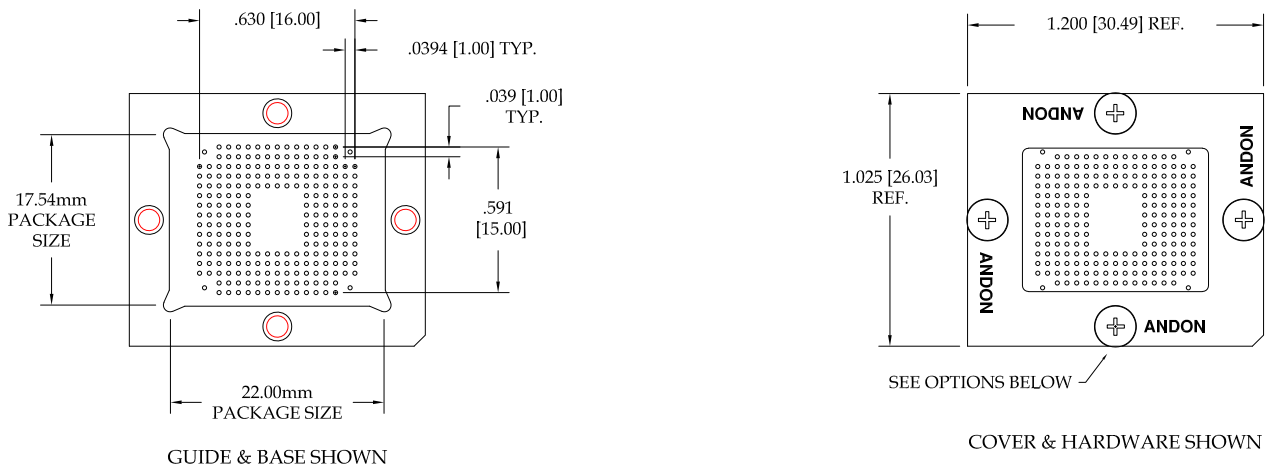

Fig. 15 230 Pins
Thru-Hole: 694-230D-TH-491-R27-L14-1
Surface Mount: 694-230D-SM-500-R27-L14-1
Rollerball®: 694-230D-SM-RB593-R27-L14-1

©Copyright 2023 Andon Electronics Corporation. All Rights Reserved. This material is protected under US and other copyrights and may not be copied, sold, or redistributed in any form without written permission of Andon Electronics Corporation. Copyrights and trademarks are property of their respective companies. We reserve the right to change specifications without notice. Andon makes no warranty, expressed or implied, as to the suitability of the sockets for the intended purpose.

Rollerball® U.S. PATENT
CANADIAN PATENT

"ANDON PROPRIETARY INFORMATION"
RoHS Compliant

*Sockets are not drawn to scale GPIXEL INC. 05/10/2023

GPIXEL INC. *Continued* Image Sensor Socket Footprints Units: in [mm]

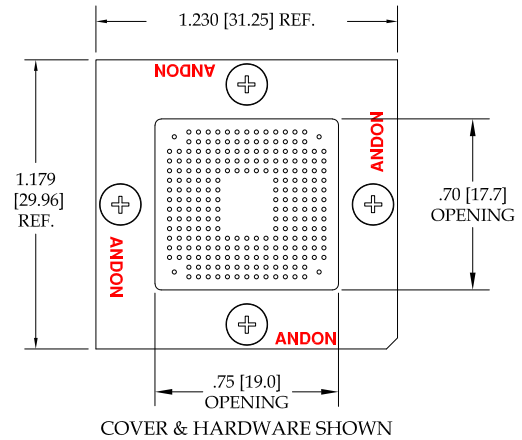
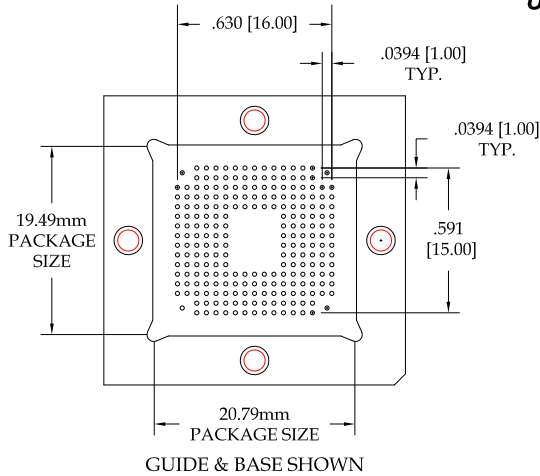

Fig. 16 230 Pins
Thru-Hole: 694-230E-TH-491-R27-L14-1
Surface Mount: 694-230E-SM-500-R27-L14-1
Rollerball®: 694-230E-SM-RB593-R27-L14-1

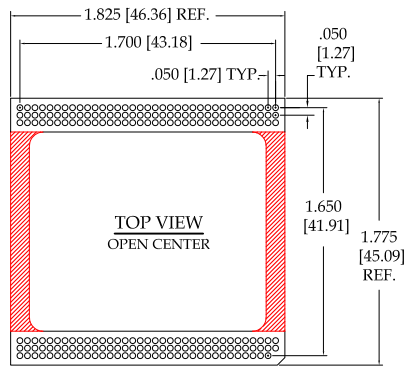

Fig. 17 209 Pins
Thru-Hole: 10-35-07A-209-400T4-R27-L14
Surface Mount: 10-35-07A-209-414T4-R27-L14
Rollerball®: 10-35-07A-209-RB501T4-R27-L14
 REFER TO LAST PAGE FOR CARRIER OPTIONS
 RED SECTIONS OF INSULATOR CAN BE OMITTED AND
 THIS CARRIER USED IN THEIR PLACE:
Carrier/Sips: 9-10-35-07A-209-XXX-R27-L14-SIP

Replace "-XXX" with choice of terminal

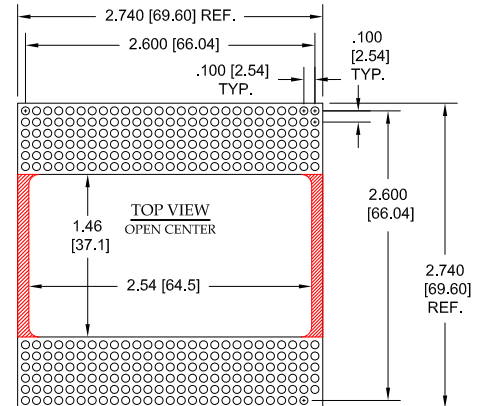

Fig. 18 323 Pins
Thru-Hole: 575-27-01-323-01P28-R27-L14
Surface Mount: 575-27-01-323-93P28-R27-L14
Rollerball®: 575-27-01-323-RB338K-R27-L14
 REFER TO LAST PAGE FOR CARRIER OPTIONS
 RED SECTIONS OF INSULATOR CAN BE OMITTED AND
 THIS CARRIER USED IN THEIR PLACE:
Carrier/Sips: 9-575-27-01-323-XXX-R27-L14-SIP

Replace "-XXX" with choice of terminal

GPIXEL INC. *Continued* Image Sensor Socket Footprints Units: in [mm]

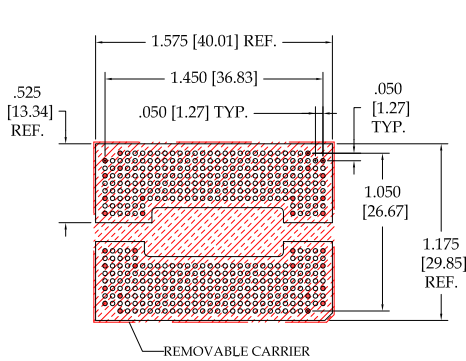

Fig. 19 454 Pins
Thru-Hole: 9-10-30-15-454-274UM-R27-L14-SIP
Surface Mount: 9-10-30-15-454-315UM-R27-L14-SIP
Rollerball®: 9-10-30-15-454-RB338UM-R27-L14-SIP

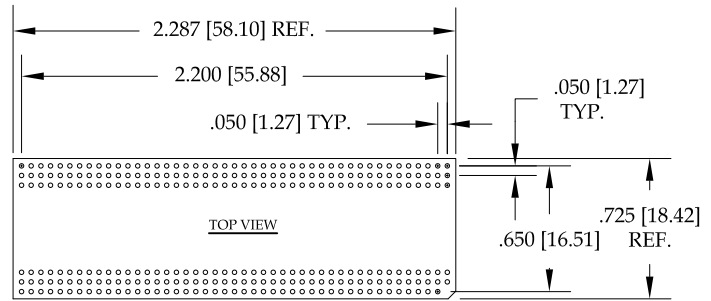

Fig. 20 269 Pins
Thru-Hole: 10-45-01-269-400T4-R27-L14
Surface Mount: 10-45-01-269-414T4-R27-L14
Rollerball®: 10-45-01-269-RB501T4-R27-L14

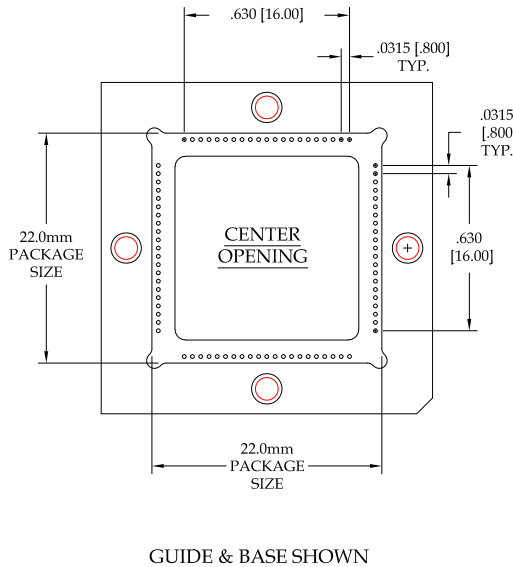
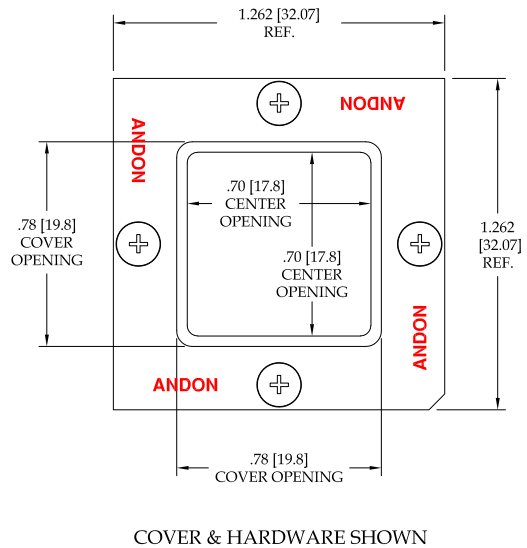

Fig. 21 84 Pins
Thru-Hole: 684-84-TH-491-R27-L14-1
Surface Mount: 684-84-SM-500-R27-L14-1
Rollerball®: 684-84-SM-RB593-R27-L14-1



GPIXEL INC. *Continued*

Image Sensor Socket Footprints

Units: in [mm]

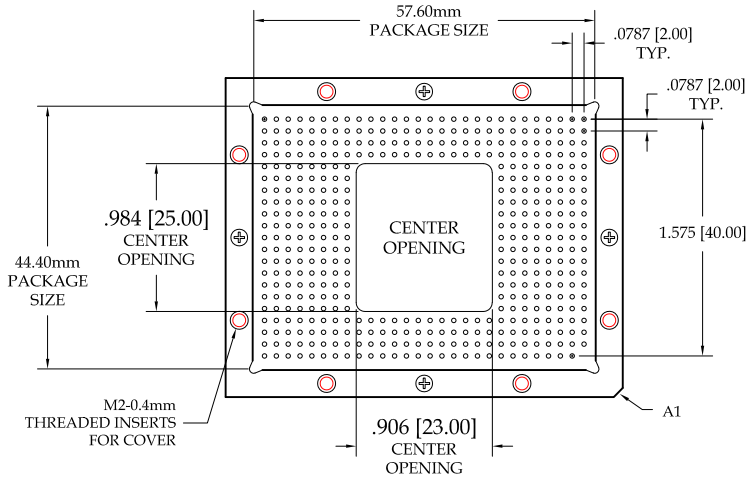

GUIDE, HARDWARE & BASE SHOWN

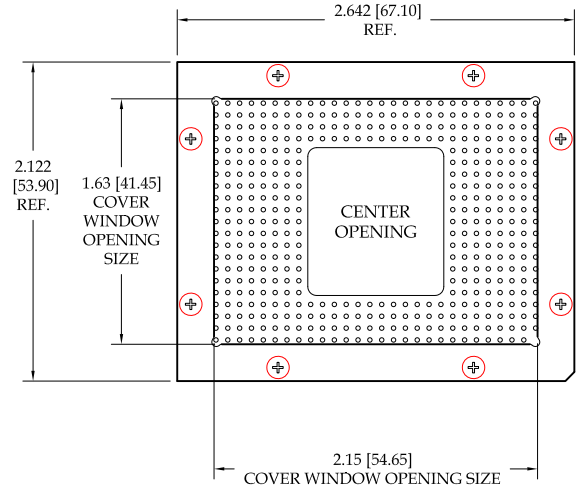

COVER & HARDWARE SHOWN

Fig. 22 431 Pins

- Thru-Hole: 692-431-TH-491-R27-L14
- Surface Mount: 692-431-SM-500-R27-L14
- Rollerball®: 692-431-SM-RB593-R27-L14

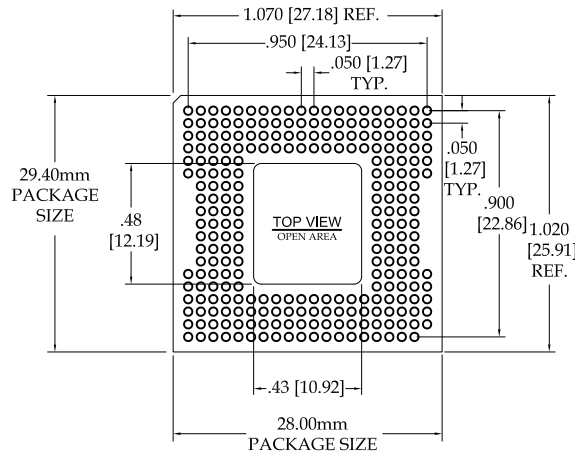

Fig. 23 255 Pins

- Thru-Hole: 10-20-06-255-400T4-R27-L14
- Surface Mount: 10-20-06-255-414T4-R27-L14
- Rollerball®: 10-20-06-255-RB501T4-R27-L14

Why Heat Sink Sockets™?

With the rising demand for higher resolution cameras, image sensors are getting increasingly hotter. Optoelectronic sensors and gas sensors have always generated a lot of heat. As heat increases, noise increases geometrically jeopardizing the proper functioning of the sensor. Now there's a solution...

Andon's patented Heat Sink Sockets™ combine the heat dissipation properties of a heat sink with the benefits of using a socket - namely, to avoid exposing the device to high temp solder and contaminating cleaning solutions, as well as to enable easy removal of the device from the PCB without the labor and risk of de-soldering. Also unlike a thermoelectric cooler (TEC), Heat Sink Sockets™ draw the heat downward and away from the device body, require no power and take up little space.

How Do They Work?

Using a Fiberglass insulator encased in an aluminum body, our patented Heat Sink Socket™ design draws heat away from the device and disperses it through a series of cooling fins. An optional copper layer in the PCB can provide additional heat / noise dissipation, as needed.

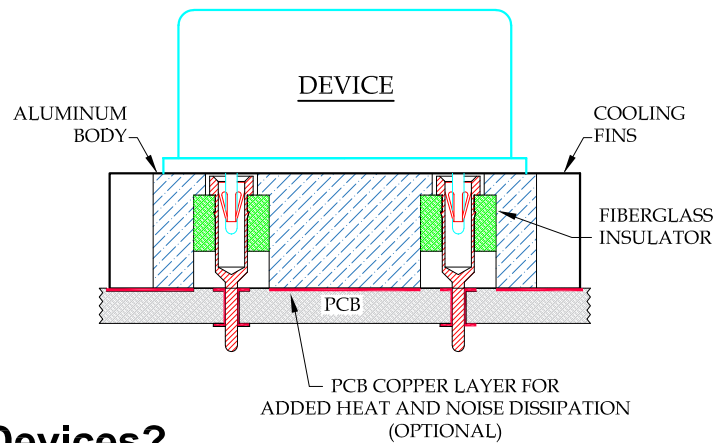

For What Types Of Devices?

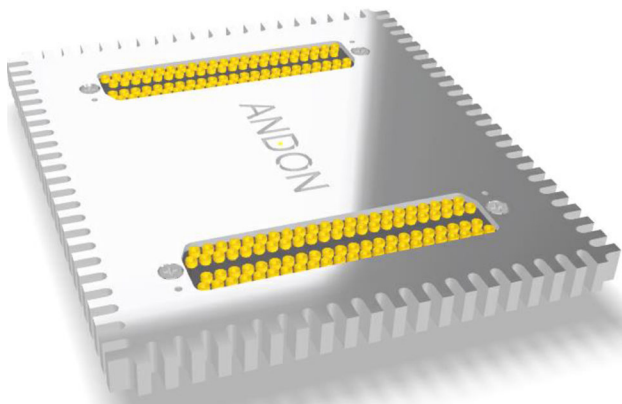
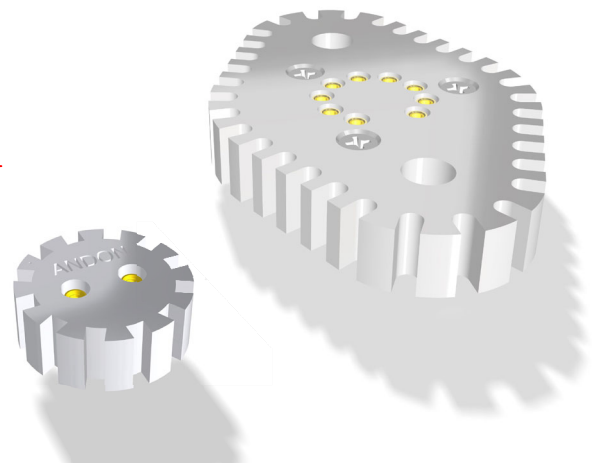

Image Sensors

PATENTED



Optoelectronic and Gas sensors

©Copyright 2023 Andon Electronics Corporation. All Rights Reserved. This material is protected under US and other copyrights and may not be copied, sold, or redistributed in any form without written permission of Andon Electronics Corporation. Copyrights and trademarks are property of their respective companies. We reserve the right to change specifications without notice. Andon makes no warranty, expressed or implied, as to the suitability of the sockets for the intended purpose.

'ANDON PROPRIETARY INFORMATION'
RoHS Compliant

*Sockets are not drawn to scale GPIXEL INC. 05/10/2023

GPIXEL INC. Continued
Image Sensor Socket Footprints

Units: in [mm]

PATENTED

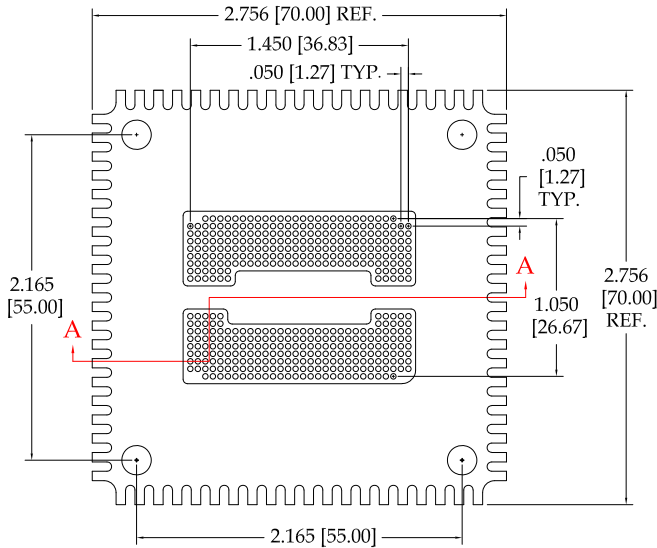
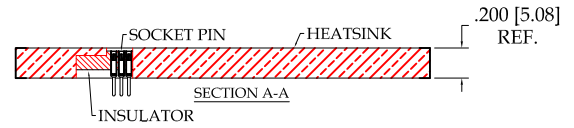
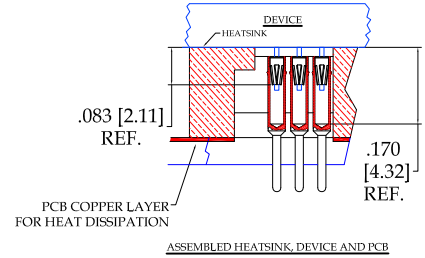

Fig. 24

Thru-Hole: 10-30-15-454-275UM-R27-L14-HS1



PATENTED

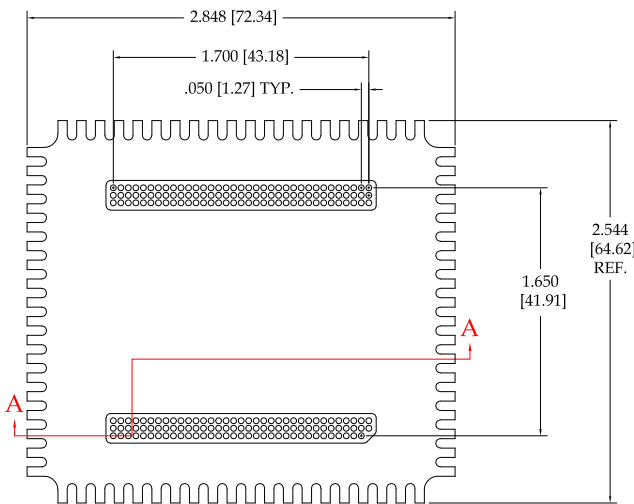
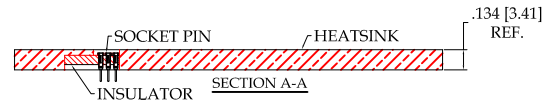
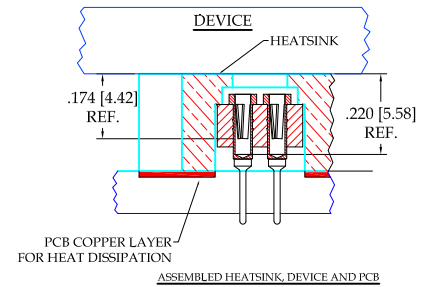

Fig. 25

Thru-Hole: 10-35-07-209-400T4-R27-L14-HS1



GPIXEL INC. *Continued*

Image Sensor Terminal Options

Units: in [mm]

THRU HOLE OPTION

- 01M

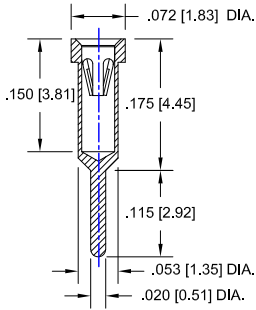

- 01P28

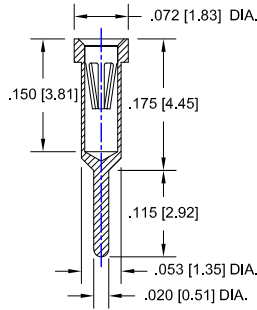

-75M

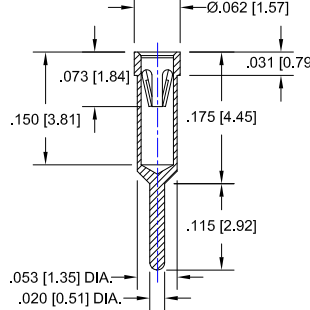

- 80M

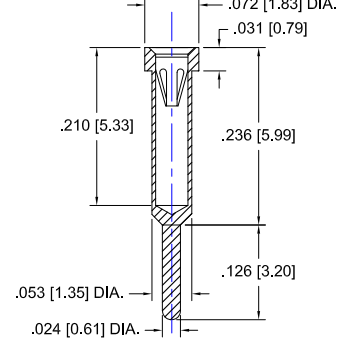

-274UM

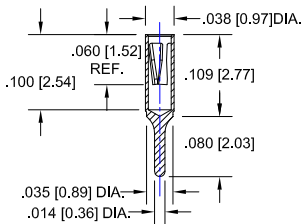

- 275UM

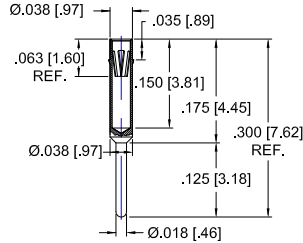

- 347T

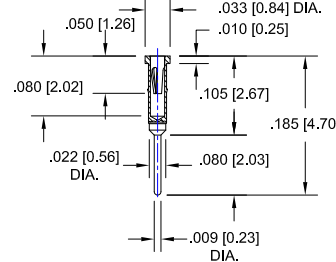

- 400T4

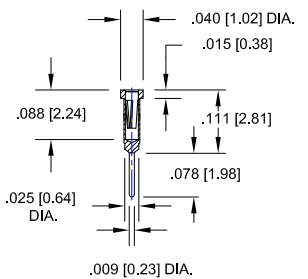

- 491

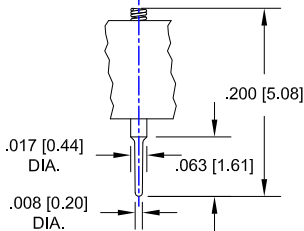

Technical Information

Plating: RoHS COMPLIANT

R27 TERMINAL: GOLD / CONTACT: GOLD

R29 TERMINAL: MATTE TIN / CONTACT: GOLD

R32 TERMINAL: MATTE TIN / CONTACT: TIN

OTHER PLATINGS AVAILABLE

Material:

Insulator: Hi-Temp UL 94V-O
Terminal: Brass, per ASTM-B16
Contact: BeCu, Per ASTM-B194

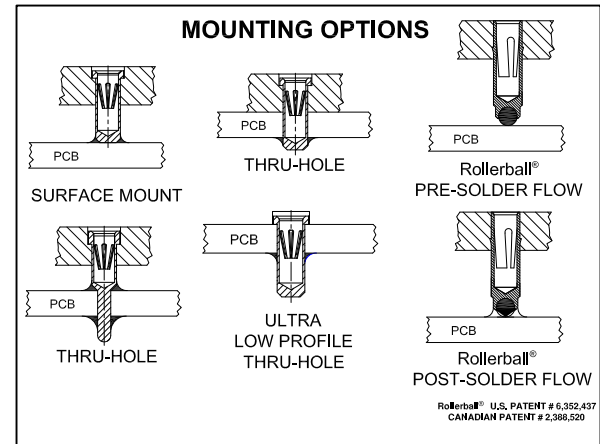

©Copyright 2023 Andon Electronics Corporation. All Rights Reserved. This material is protected under US and other copyrights and may not be copied, sold, or redistributed in any form without written permission of Andon Electronics Corporation. Copyrights and trademarks are property of their respective companies. We reserve the right to change specifications without notice. Andon makes no warranty, expressed or implied, as to the suitability of the sockets for the intended purpose.

Rollerball® U.S. PATENT # 6,352,437
CANADIAN PATENT # 2,388,520

"ANDON PROPRIETARY INFORMATION"

RoHS Compliant

*Sockets are not drawn to scale GPIXEL INC. 05/10/2023

GPIXEL INC. Continued
Image Sensor Terminal Options
Units: in [mm]

SURFACE MOUNT OPTION

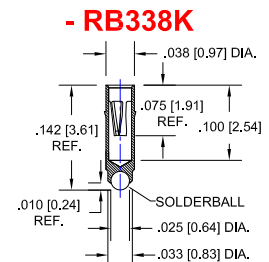
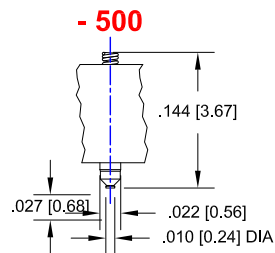
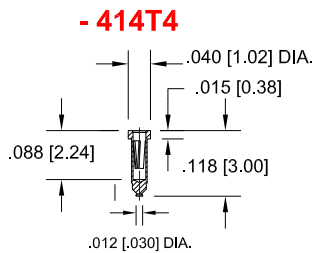
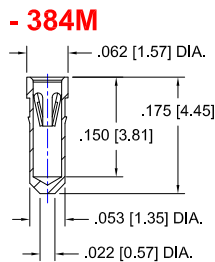
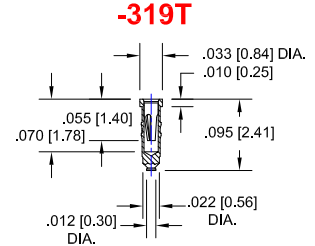
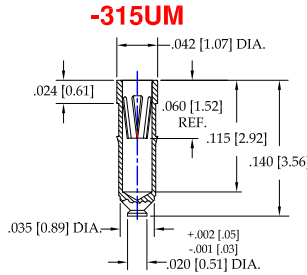
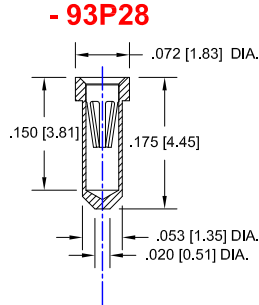
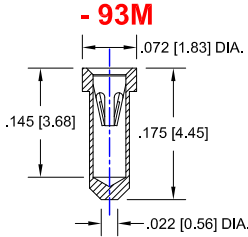

ROLLERBALL® SOCKET

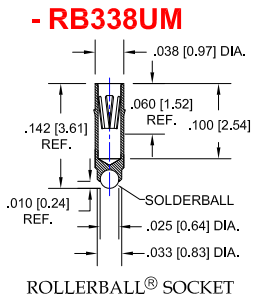

ROLLERBALL® SOCKET

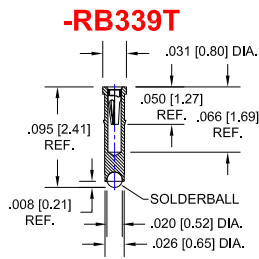

ROLLERBALL® SOCKET

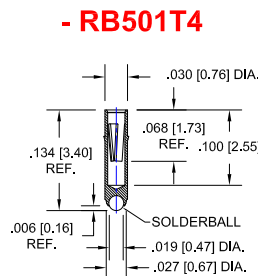

ROLLERBALL® SOCKET

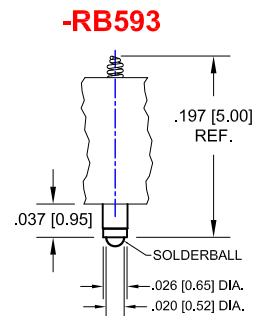

ROLLERBALL® SOCKET

Terminal Acceptance and Forces							
Thru Hole Terminals				Surface Mount Terminals			
Thru Hole Terminal	Accepts Pin Diameter	Insertion Force	Withdrawal Force	Surface Mount Terminal	Accepts Pin Diameter	Insertion Force	Withdrawal Force
-400T4	Ø.012 [Ø0.30]	1.05 oz Max	0.32 oz Min	-414T4	Ø.012 [Ø0.30]	1.05 oz Max	0.32 oz Min
-01M	Ø.018 [Ø0.46]	1.60 oz Max	0.50 oz Min	-93M	Ø.018 [Ø0.46]	1.60 oz Max	0.50 oz Min
-80M	Ø.018 [Ø0.46]	1.60 oz Max	0.50 oz Min	-93M	Ø.018 [Ø0.46]	1.60 oz Max	0.50 oz Min
-491	-	-	-	-500	-	-	-
-75M	Ø.018 [Ø0.46]	1.60 oz Max	0.50 oz Min	-384M	Ø.018 [Ø0.46]	1.60 oz Max	0.50 oz Min
-347T	Ø.010 [Ø0.30]	1.00 oz Max	0.30 oz Min	-319T	Ø.010 [Ø0.46]	1.00 oz Max	0.30 oz Min
				-RB339T	Ø.010 [Ø0.30]	1.00 oz Max	0.30 oz Min
				-RB338K	Ø.018 [Ø0.46]	1.24 oz Max	0.50 oz Min
				-RB501T4	Ø.012 [Ø0.30]	1.05 oz Max	0.32 oz Min
				-RB593	-	-	-

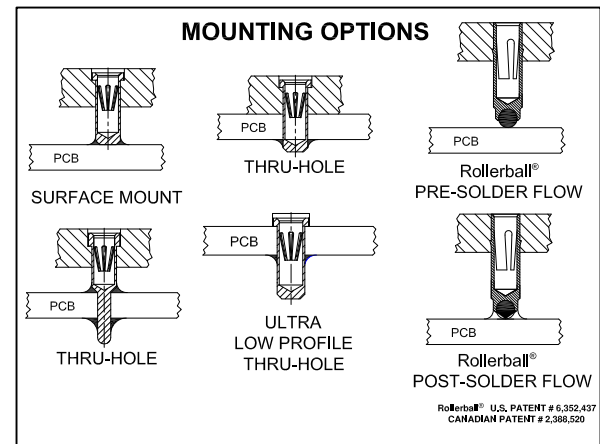

©Copyright 2023 Andon Electronics Corporation. All Rights Reserved. This material is protected under US and other copyrights and may not be copied, sold, or redistributed in any form without written permission of Andon Electronics Corporation. Copyrights and trademarks are property of their respective companies. We reserve the right to change specifications without notice. Andon makes no warranty, expressed or implied, as to the suitability of the sockets for the intended purpose.

Rollerball® U.S. PATENT CANADIAN PATENT

"ANDON PROPRIETARY INFORMATION"
RoHS Compliant

*Sockets are not drawn to scale GPIXEL INC. 05/10/2023

Socket Mounting Options

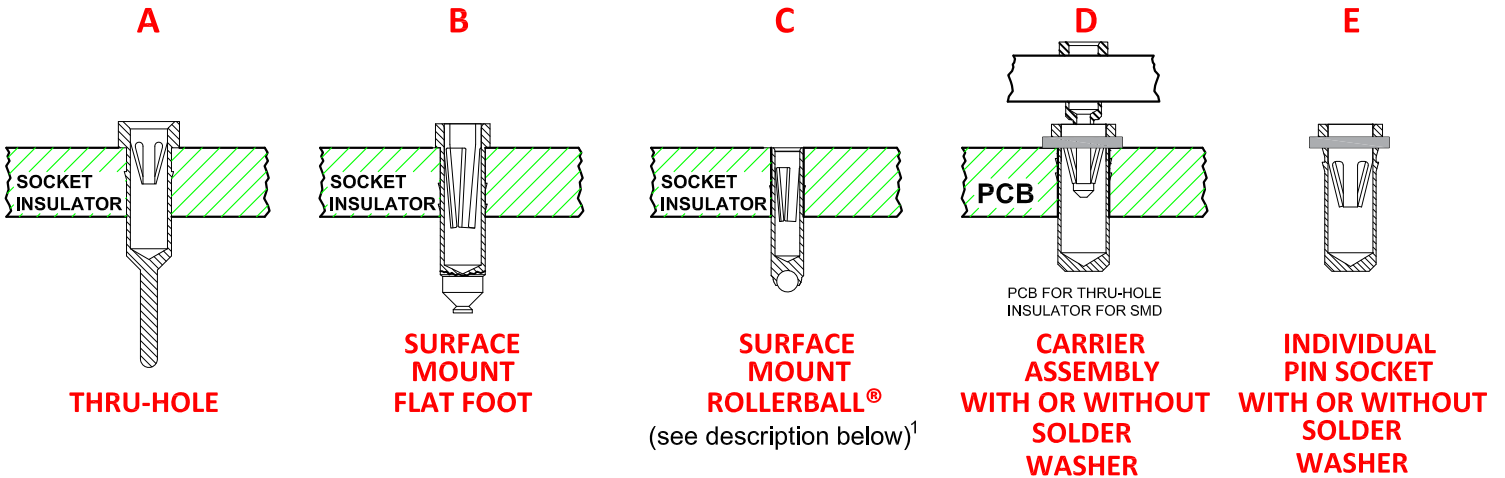

¹Andon's patented Rollerball® socket terminal option provides more accurate soldering, a stronger connection, and improved electrical connectivity - especially under shock and vibration - than other solder ball terminal designs. Better yet, it can enable you to avoid expensive rework and scrap - especially with larger PCBs where coplanarity is an inherent challenge.

The bottom of these terminals has a radiused hole, to prevent gas entrapment. The terminal is crimped over the solder ball beyond its hemisphere, encapsulating it - leaving just enough of the solder ball exposed to provide sufficient solder without the solder bridging common in conventional solder ball terminal designs.

With this unique design, the critical distance between the terminal and the PC board pad is typically reduced from .036"-.040" to .018"-.022". As such, the solder becomes part of the "anchor" cross-section - providing additional mechanical strength to the connection, as well as improved electrical connectivity. Because it also provides controlled dispersion of solder, this encapsulated solder ball reduces the risk of solder bridging inherent in conventional solder ball terminal designs.

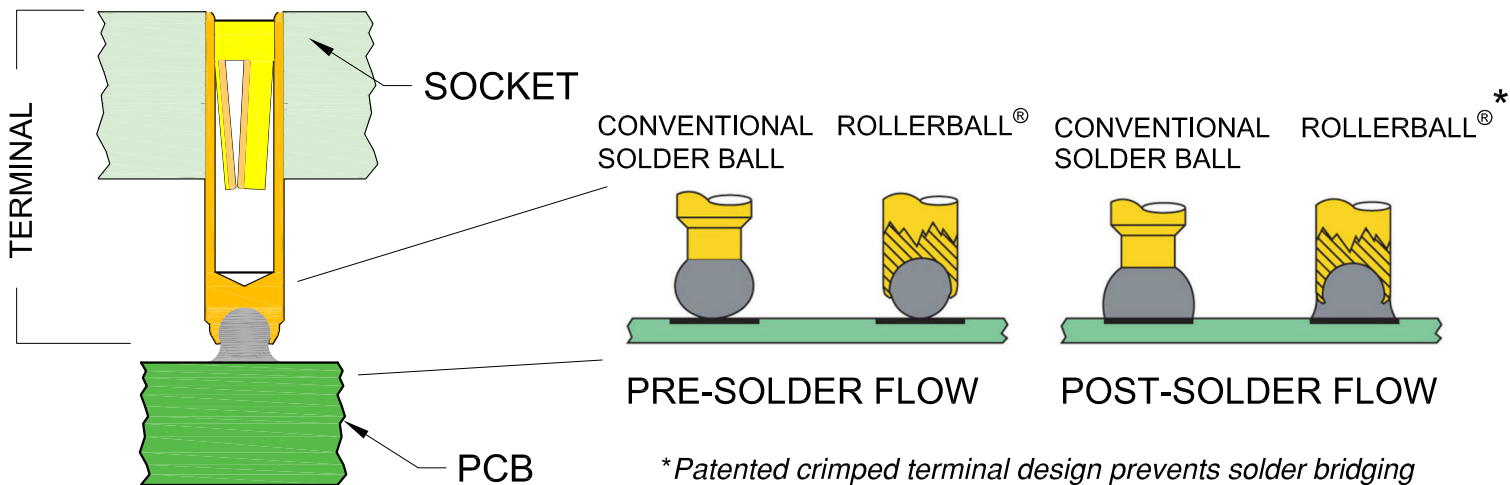

For fast, accurate placement of SIP sockets and ultra-low profile terminals

Phase 1:
Receive Carrier Assemblies designed to your pin layout.



Phase 2:
Place carrier assemblies onto PCB; run through your soldering process.



Phase 3:
Remove carrier and plug in your device; discard carrier.

DIP

Before Soldering

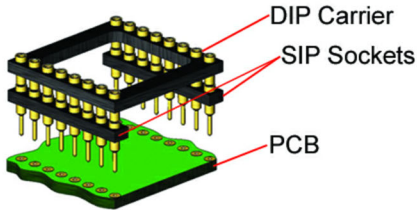

During Soldering



After Soldering

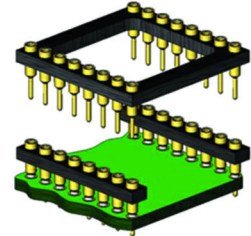

ULTRA-LOW PROFILE SIP

Before Soldering

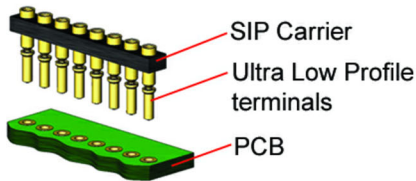

During Soldering

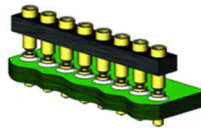

After Soldering

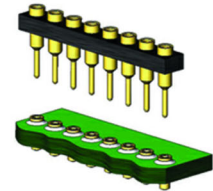

ULTRA-LOW PROFILE PGA

Before Soldering

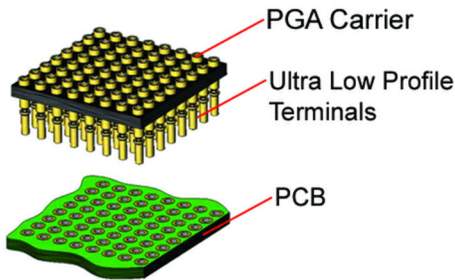

During Soldering

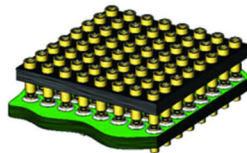

After Soldering

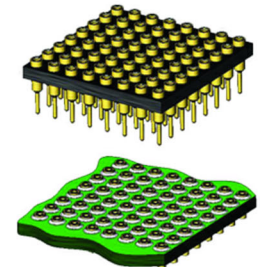

ULTRA LOW PROFILE DIP

Before Soldering

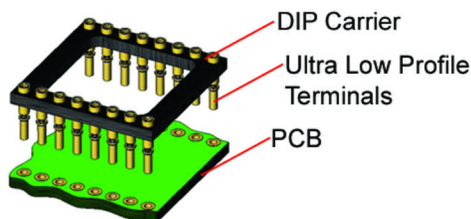

During Soldering

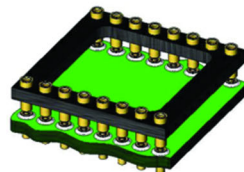

After Soldering

